

NOTES: UNLESS OTHERWISE SPECIFIED,
FASTEN ALL PARTS WITH
1 1/4" DRYWALL SCREWS

MULTIPURPOSE GLUE SUCH AS
LIQUID NAILS® MAY BE USED ON
ALL JOINTS IF OFFICE WILL
BE PERMANENT

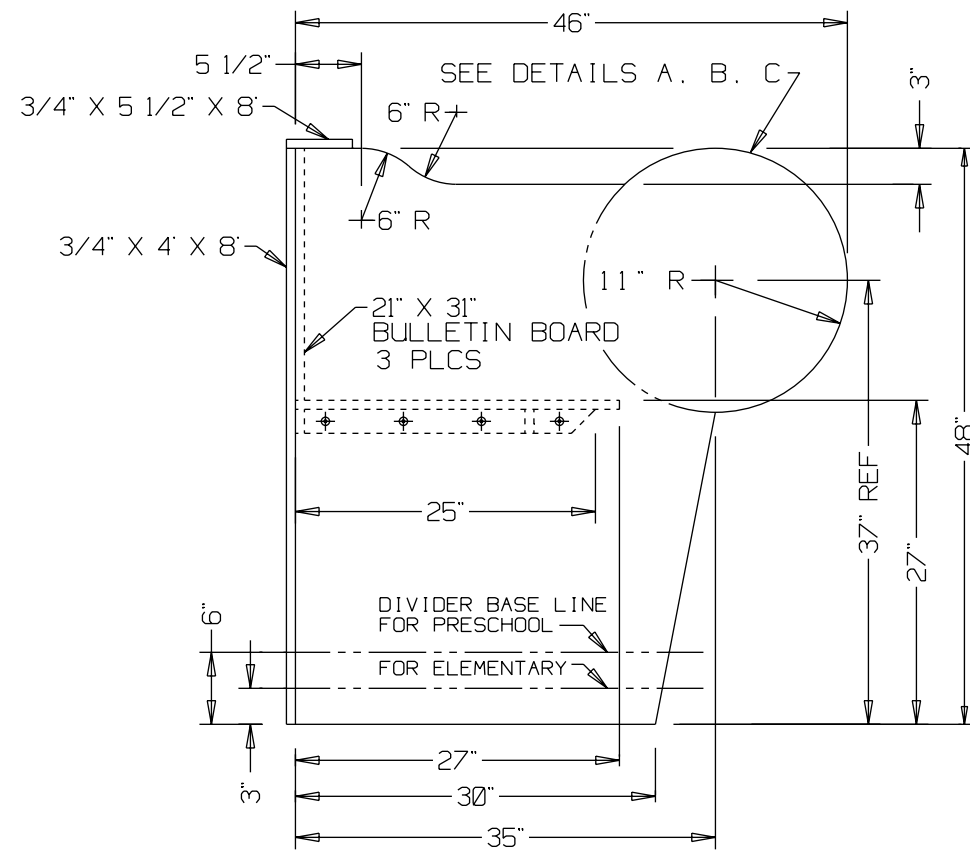

SIDE VIEW

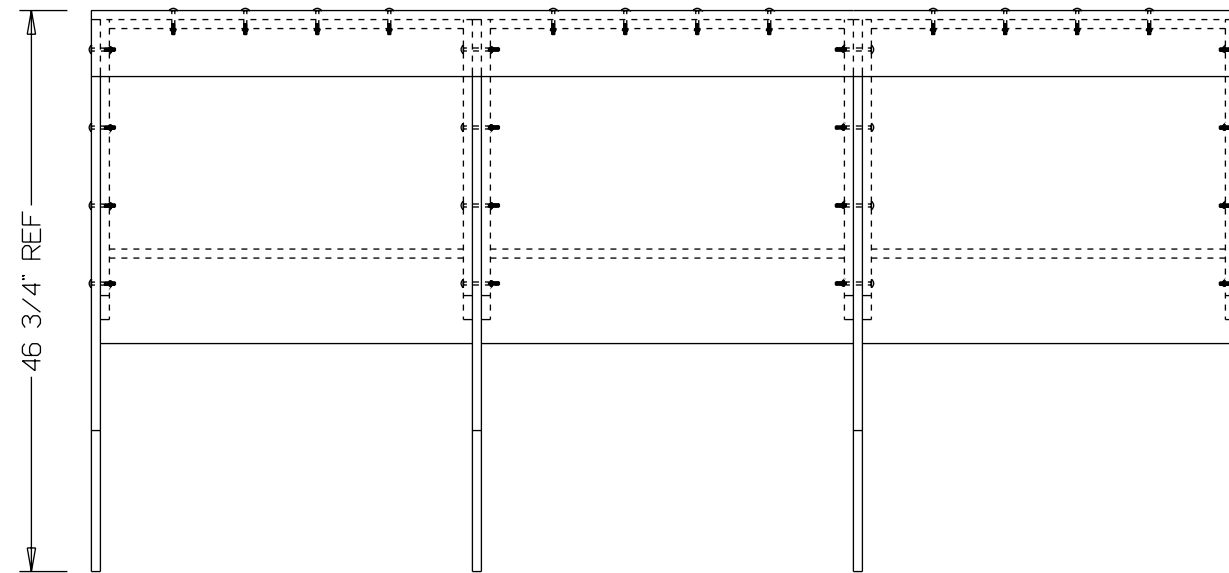

TOP VIEW

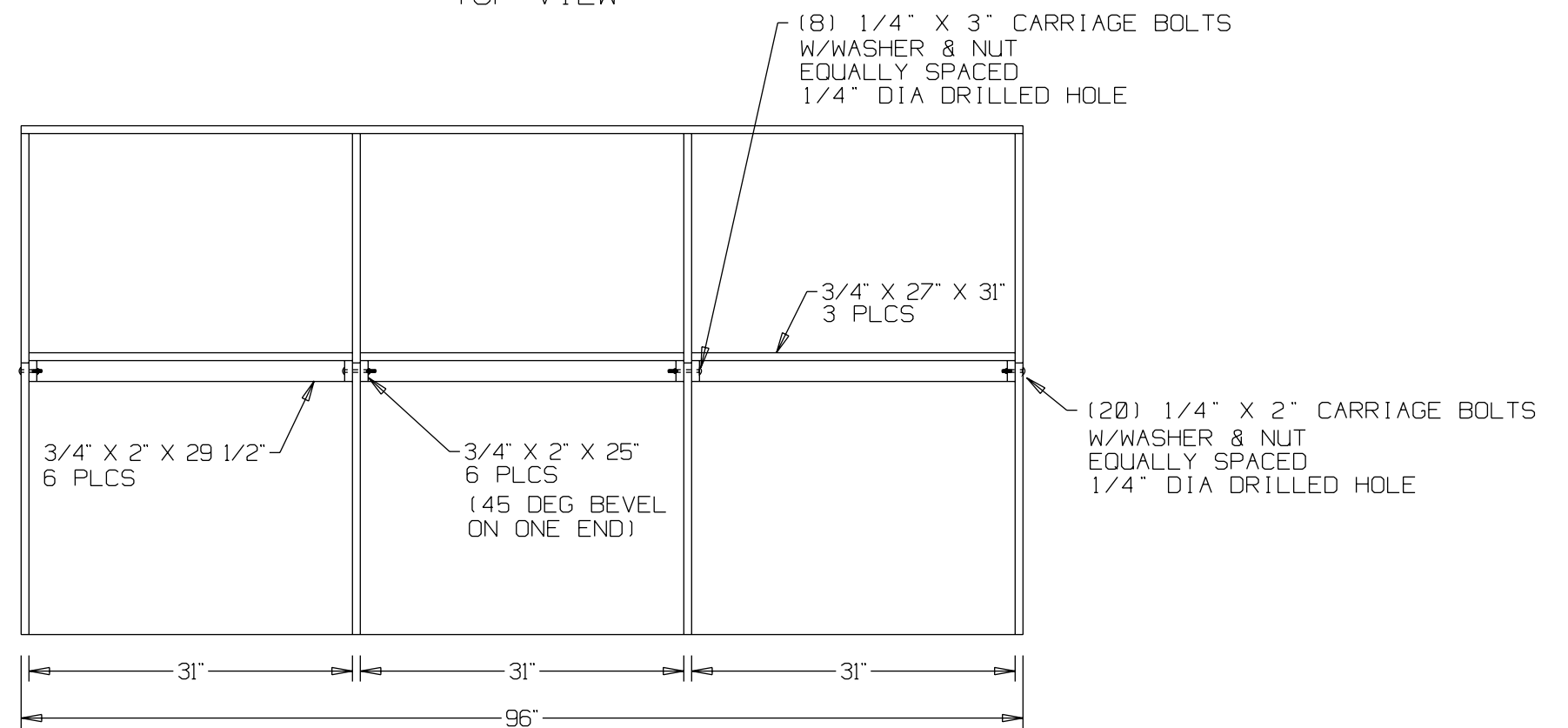

FRONT VIEW

© 1995 Accelerated Christian Education, Inc.
All rights reserved. Printed in the United States of America.
This publication may not be reproduced in whole or in part
in any form or by any means without permission from
Accelerated Christian Education, Inc.

ACCELERATED CHRISTIAN EDUCATION
STUDENT OFFICE

DWG. NO. 0003	REV. 950316-0	SHEET 2 OF 3
------------------	------------------	-----------------